

Thermoplastics pipes and fittings with profiled outer and smooth inner surfaces

Part 1: Dimensions

DIN
16961-1

ICS 23.040.20; 23.040.45

Supersedes
February 1989 edition.

Rohre und Formstücke aus thermoplastischen Kunststoffen mit profilierter Wandung und glatter Rohinnenfläche – Teil 1: Maße

In keeping with current practice in standards published by the International Organization for Standardization (ISO), a comma has been used throughout as the decimal marker.

Contents

	Page		Page
Foreword	1	5.1.3 Length	5
1 Scope	1	5.1.4 Profile	5
2 Normative references	2	5.1.5 Designation	5
3 Concepts	2	5.2 Fittings	5
3.1 Nominal diameter	2	5.2.1 General	5
3.2 Outside diameter	2	5.2.2 Gusseted bends	6
4 Pipe series	2	5.2.3 45° branches	7
5 Dimensions and designation	2	5.2.4 Transition pipes	9
5.1 Pipes	2	5.2.5 PE-HD adapters	10
5.1.1 Inside diameter	2	6 Joints	11
5.1.2 Outside pipe diameter	5		

Foreword

This standard has been prepared by Technical Committee *Profilierte Rohre aus thermoplastischen Kunststoffen mit glatter Innenwand* of the *Normenausschuss Kunststoffe* (Plastics Standards Committee).

Amendments

This standard differs from the February 1989 edition in that specifications for outside diameters have been included and the standard has been revised in form and substance.

Previous editions

DIN 16961-1: 1977-09, 1989-02.

All dimensions are in millimetres.

1 Scope

This standard specifies dimensions and tolerances for thermoplastics pipes and fittings with profiled outer and smooth inner surfaces.

For the purposes of this standard, profiled pipes are those with profiled outside surfaces, flanged pipes, helically wound pipes, and pipes with foamed inserts in their walls.

NOTE: Fittings manufactured differently may also be used in pipework.

Pipes manufactured in accordance with this standard may also be used as components in process engineering.

NOTE: Any relevant European Standards shall also be observed.

Continued on pages 2 to 11.

Translation by DIN-Sprachendienst.

In case of doubt, the German-language original should be consulted as the authoritative text.

2 Normative references

This standard incorporates, by dated or undated reference, provisions from other publications. These normative references are cited at the appropriate places in the text, and the titles of the publications are listed below. For dated references, subsequent amendments to or revisions of any of these publications apply to this standard only when incorporated in it by amendment or revision. For undated references, the latest edition of the publication referred to applies.

DIN 323-1 Preferred numbers and preferred number series – Basic, calculated and rounded values

DIN 16961-2 Thermoplastics pipes and fittings with profiled outer and smooth inner surfaces – Technical delivery conditions

DIN 19537-1 High-density polyethylene (PE-HD) pipes and fittings for drains and sewers – Dimensions

DVS-Richtlinie 2207-1 *Schweißen von thermoplastischen Kunststoffen – Heizelementschweißen von Rohren, Rohrleitungsteilen und Tafeln aus PE-HD* (Welding of high-density polyethylene pipes and pipe fittings for gas and water pipework)¹⁾

DVS-Richtlinie 2209-1 *Schweißen von thermoplastischen Kunststoffen – Extrusionsschweißen – Verfahren, Merkmale* (Extrusion welding of thermoplastics – Welding procedure and characteristics)¹⁾

3 Concepts

3.1 Nominal diameter

The diameter, in millimetres, on which the pipe size is based (outside or inside diameter); designated by d_n .

3.2 Outside diameter

The distance between any two points on the outer circumference of the pipe or spigot end of a fitting, located on a diagonal across the pipe bore.

4 Pipe series

Pipe classification is based on the ring stiffness, S_{R24} , as specified in table 1, with the ring stiffness values being based on the series R 10 as in DIN 323-1.

Table 1: Ring stiffness

Pipe series no.	1	2	3	4	5	6	7
Minimum ring stiffness, S_{R24} , in kN/m ²	2	4	8	16	31,5	63	125

S_{R24} is a parameter required in pipe design which cannot be accurately calculated for pipes with profiled outer surfaces, for flanged pipes, or for pipes made of composite materials. In these cases, S_{R24} is to be determined as in DIN 16961-2.

5 Dimensions and designation

5.1 Pipes

5.1.1 Inside diameter

Pipe sizes are based on the inside diameter, d_i , corresponding to series R 10 as in DIN 323-1 for inside diameters from 100 mm to 630 mm, and to series R 20 as in DIN 323-1 for inside diameters from 710 mm to 2800 mm. Commonly used inside diameters not corresponding to either series R 10 or R 20 have been identified by a footnote in table 2.

NOTE: Exact dimensions shall be as specified in the relevant company standard.

Pipes shall be manufactured with socket and spigot end (type I or II) or with plain ends (type III). Dimensions d_i , d_a , l_1 and l_2 shall be at the manufacturer's discretion.

The designs shown in figure 1 are for illustrative purposes only, but the dimensions shall be as specified in table 2.

¹⁾ Obtainable from Verlag für Schweißen und verwandte Verfahren (DVS-Verlag) GmbH, Postfach 10 19 65, 40010 Düsseldorf, Germany.

Type I
Socket pipe for welding

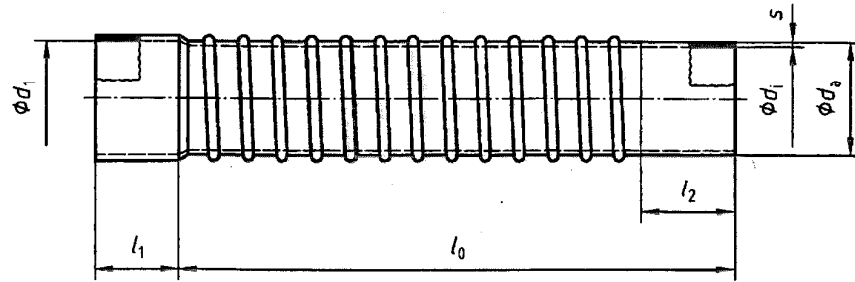

Type II
Socket pipe with seal

Type III
Pipe with plain ends

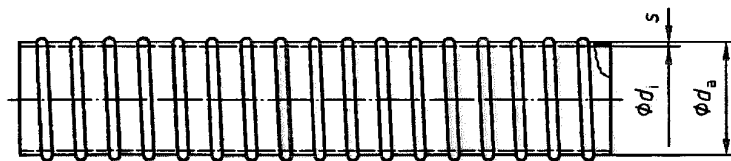

The illustration shows a type III pipe. A greater wall thickness at the pipe ends is permissible.

In both illustrations,
 d_i is the pipe inside diameter;
 d_a is the pipe outside diameter;
 d_1 is the socket inside diameter;
 l_0 is the overall length;
 l_1 is the socket length;
 l_2 is the spigot length

Figure 1: Pipes (notation)

Table 2: Tolerances on pipe inside diameter

Nominal size DN	Pipe inside diameter, d_i	Lower deviation for series 1 to 7	Limit deviations ²⁾	
			Upper deviation for series 1 to 4	for series 5 to 7
100	100	- 3	+ 1	+ 2
125	125	- 3	+ 2	+ 2
150	150 ¹⁾	- 4	+ 2	+ 3
200	200	- 5	+ 3	+ 4
250	250	- 6	+ 4	+ 5
300	300 ¹⁾	- 8	+ 4	+ 6
315	315	- 8	+ 5	+ 6
350	350 ¹⁾	- 9	+ 5	+ 7
400	400	-10	+ 6	+ 8
450	450 ¹⁾	-11	+ 7	+ 9
500	500	-13	+ 7	+10
600	600 ¹⁾	-15	+ 9	+12
630	630	-16	+ 9	+13
700	700 ¹⁾	-18	+10	+14
800	800	-20	+12	+16
900	900	-23	+13	+18
1 000	1 000	-25	+15	+20
1 200	1 200 ¹⁾	-30	+18	+24
1 400	1 400	-35	+21	+28
1 500	1 500 ¹⁾	-38	+22	+30
1 600	1 600	-40	+24	+32
1 800	1 800	-45	+27	+36
2 000	2 000	-50	+30	+40
2 200	2 200 ¹⁾	-55	+33	+44
2 240	2 240	-56	+34	+45
2 400	2 400 ¹⁾	-60	+36	+48
2 500	2 500	-63	+37	+50
2 600	2 600 ¹⁾	-65	+39	+52
2 800	2 800	-70	+42	-
3 000	3 000 ¹⁾	-75	+45	+60
3 500	3 500	-87	+52	+70
3 600	3 600	-90	+54	+72

1) Does not correspond with series R 10 or R 20 as in DIN 323-1.
2) Limit deviations have been calculated as follows:
for pipe series 1 to 4: $d - 0,025 d_i$ up to $d + 0,015 d_i$;
for pipe series 5 to 7: $d - 0,025 d_i$ up to $d + 0,02 d_i$.

5.1.2 Outside diameter

Table 3: Tolerances on pipe outside diameter

Nominal size DN	Pipe outside diameter, d_a	Limit deviation	
		for pipes with foamed inserts	for pipes with profiled outer surface
100	110	± 5	± 10
110	110	± 5	± 10
125	125	± 5	± 10
140	140	± 5	± 10
150	160	± 5	± 10
160	160	± 5	± 10
180	180	± 5	± 10
200	200	± 5	± 10
225	225	± 5	± 10
250	250	± 5	± 10
300	315	$\pm 0,02 d_a$	$\pm 0,04 d_a$
400	400	$\pm 0,02 d_a$	$\pm 0,04 d_a$
500	500	$\pm 0,02 d_a$	$\pm 0,04 d_a$
600	630	± 15	± 30
700	710	± 15	± 30
800	800	± 15	± 30
900	900	± 15	± 30
1 000	1 000	± 15	± 30
1 200	1 200	± 15	± 30

5.1.3 Length

Pipes shall be supplied in overall lengths of 2 m, 3 m, 4 m, 5 m, 6 m, 10 m and 12 m, or, by agreement, in approximate and fixed lengths. Ends shall be cut square to the pipe axis.

Table 4: Limit deviations for pipe length

Overall length, l_0	Limit deviations at $(23 \pm 2)^\circ\text{C}$, in mm
Approximate length	± 100
Fixed length (up to 12 m)	+ 50 0

5.1.4 Profile

The type of profile shall be at the manufacturer's discretion and shall be described in the product data sheet. The surface profile shall be selected to suit the ring stiffness determined in accordance with DIN 16961-2.

5.1.5 Designation

Designation of a series 4 type I PE-HD pipe, of size DN 1000, with an overall length of 6 m:

Pipe DIN 16961 – DN 1000 × 6 – 4 I – PE-HD

5.2 Fittings

5.2.1 General

Fittings shall be made by joining pipe segments, and their ring stiffness shall be at least equal to that of the pipe to which they are joined. In the case of socket fittings, this applies for the socket with the spigot end inserted. The dimensions of type I, II or III fittings made by welding pipe sections shall be as in subclauses 5.2.2 to 5.2.5. Figures 2 to 4 are for illustrative purposes only and do not show the wall profile of the fittings, but the dimensions shall be as specified in tables 5 to 8.

5.2.2 Gusseted bends

- Type I gusseted bend, with socket for welding
- Type II gusseted bend, with socket and seal
- Type III gusseted bend, with plain ends

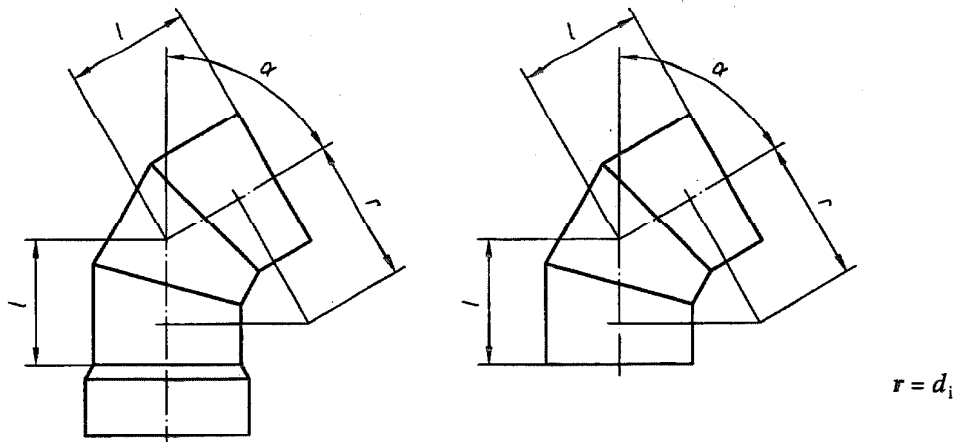

The illustration shows a type I gusseted bend.

The illustration shows a type III gusseted bend.

Figure 2: Gusseted bends

Designation of a series 3 type I PE-HD gusseted bend (SB) of size DN 1000, with $\alpha = 30^\circ$:

Bend DIN 19961 – SB – DN 1000 – 30 – 3 I – PE-HD

Table 5: Dimensions for gusseted bends

Nominal size DN	Pipe inside diameter, d_i	Wall thickness, t	Dimension l (approx.)					
			Number of segments					
			2 $\alpha = 15^\circ$	2 $\alpha = 30^\circ$	3 $\alpha = 45^\circ$	3 $\alpha = 60^\circ$	4 $\alpha = 75^\circ$	4 $\alpha = 90^\circ$
Below 300		Made to order.						
300	300	As specified by the manufacturer.	40	85	125	175	230	300
315	315		42	90	132	185	245	315
350	350		45	98	145	205	270	350
400	400		50	110	165	230	305	400
450	450		58	125	185	260	345	450
500	500		65	135	205	290	385	500
600	600		80	160	245	345	460	600
630	630		83	168	260	365	485	630
700	700		90	185	290	405	535	700
700	700		92	192	295	410	545	710
800	800		105	215	330	460	615	800
900	900		120	240	370	520	690	900
1000	1000		130	265	415	575	770	1000
1200	1200		160	320	495	695	920	1200
Over 1200			Made to order.					

5.2.3 45° branches

- Type I branch, with socket for welding
- Type II branch, with socket and seal
- Type III branch, with plain ends

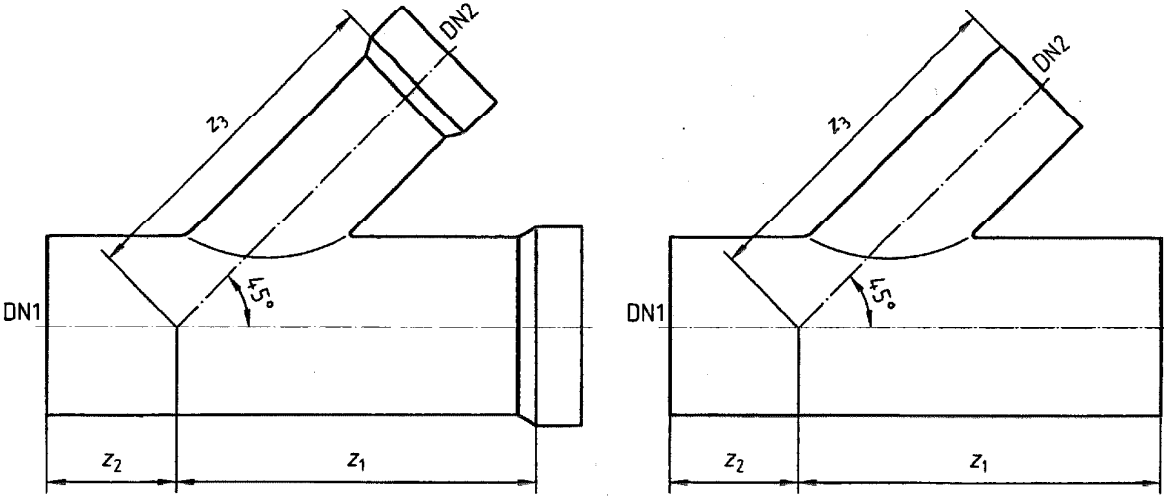

The illustration shows a type I branch.

The illustration shows a type III branch.

Figure 3: 45° branch

Designation of a series 4 type I PVC-U 45° branch (SEA) of size DN 1 = 600 and size DN 2 = 400:
Branch DIN 16961 – SEA – 600 – 400 – 4 I – PVC-U

Table 6: Dimensions for 45° branches

Nominal size DN 1	Pipe inside diameter, d_{i1} ¹⁾	Nominal size DN 2 ¹⁾	Pipe inside diameter, d_{i2}	z_1 ≈	z_2 ≈	z_3 ≈
Below 300		Made to order.				
300 315 350	300 315 350	250 300 315 350	250 300 315 350	750	350	750
400 450	400 450	250 300 315 350 400 450	250 300 315 350 400 450	900	400	900
500	500	250 300 315 350 400 450 500	250 300 315 350 400 450 500	1000	400	1000
600 630	600 630	250 300 315 350 400 450 500 600 630	250 300 315 350 400 450 500 600 630	1200	400	1200
700 800	700 800	250 300 315 350 400 450 500 600 630 700 800	250 300 315 350 400 450 500 600 630 700 800	1400	500	1400
Over 800		Made to order.				
1) DN 1 equal to or greater than DN 2.						

5.2.4 Transition pipes

Type I transition pipe, with socket for welding

Type II transition pipe, with socket and seal

Type III transition pipe, with plain ends

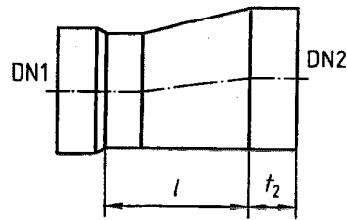

The illustration shows a type I transition pipe.

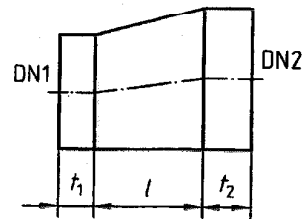

The illustration shows a type III transition pipe.

Dimensions t_1 and t_2 shall be at the manufacturer's discretion.

Figure 4: Transition pipe

Designation of a type I series 4 PE-HD transition pipe (SR) of nominal size DN 1 – 400 and nominal size D 2 = 500:

Transition pipe DIN 16961 – SR – 400 × 500 – 4 I – PE-HD

Table 7: Dimensions for transition pipes

Nominal size DN 1	Pipe inside diameter, d_{i1}	Nominal size DN 2	Pipe inside diameter, d_{i2}	Dimension l (approx.)
Below 300		Made to order.		
300 315	300 315	400 500	400 500	350 700
400	400	500 600 630	500 600 630	350 700 700
500	500	600 630 700	600 630 700	350 350 750
600 630	600 630	700 800	700 800	400 750
700	700	800 900	800 900	350 750
800	800	900 1000	900 1000	350 750
Over 800		Made to order.		

5.2.5 PE-HD adapters

Type I adapter, with socket for welding

Type II adapter, with socket and seal

Type III adapter, with plain ends

PE-HD adapters shall be made from a pipe section with a nominal size or inside diameter as specified in table 2 and a PEGMS socket as specified in DIN 19537-1.

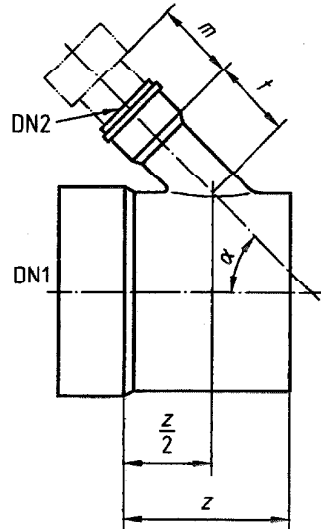

The illustration shows a type I adapter.

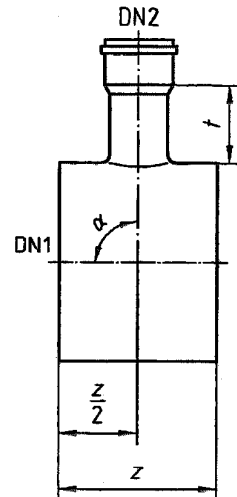

The illustration shows a type III adapter.

Dimension t shall be at the manufacturer's discretion.

Figure 5: PE-HD adapter (notation)

Designation of a series 4 type I PE-HD adapter with socket (SPA), of nominal size DN 1 = 800, fitted with a series 2 type II PEGMS socket of nominal size DN 2 = 200, welded to the adapter at an angle, α , of 45°:

Adapter DIN 16961 – SPA – 800 – 4 I – PE-HD – 45 – PEGMS – II 200 – 2

Table 8: Dimensions for adapters

Nominal size DN 1	Nominal size DN 2	Outside pipe diameter, d_1 ¹⁾	t ≈	m ≈	z ≈	α ≈
Nominal size as in table 2.	100	110	300	300	500	Optional.
	100	125				
	125	125				
	125	140				
	150	160				
	150	180				
	200	200	400	400		
	200	225				
	250	250				
	250	280				
	300	315				
	300	355				

¹⁾ As specified in DIN 19537-1.

6 Joints

Pipes and fittings shall be joined by welding (see figures 6 to 8 and 10) or by inserting a spigot end in a socket with a seal (see figure 9). Welding shall be in accordance with the specifications of DVS 2207-1 and DVS 2209-1.

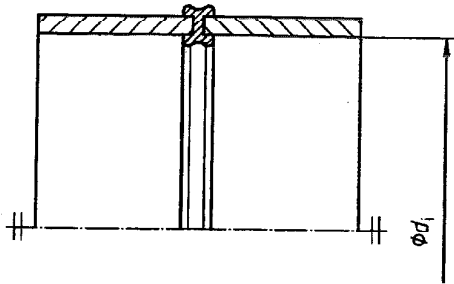

Figure 6: Heated tool butt weld

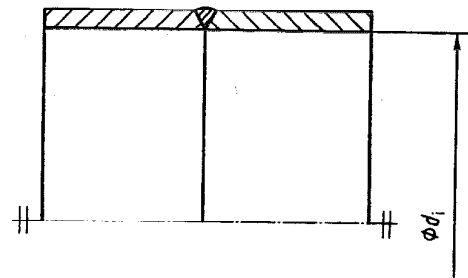

Figure 7: V extrusion butt weld
(X weld permitted for larger sizes)

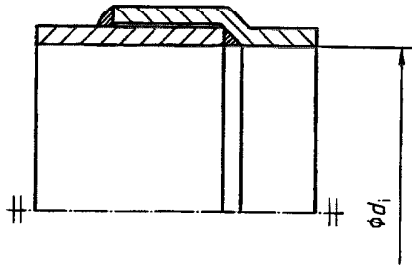

Figure 8: Socket extrusion weld
(inner weld for size DN 800 or larger)

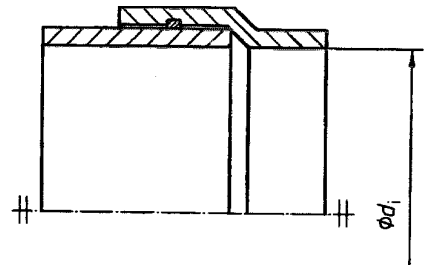

Figure 9: Push-in joint with seal
(seal type to be selected by manufacturer)

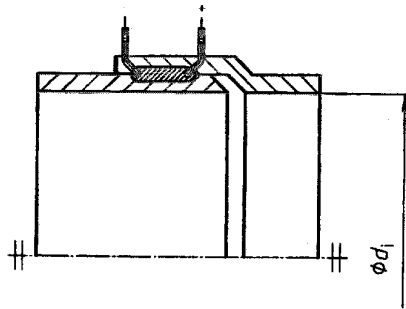

Figure 10: Socket for resistance welding for DN 300 or larger